

* Beispiel für Huber+Süner Standard-Crimpeinsatz

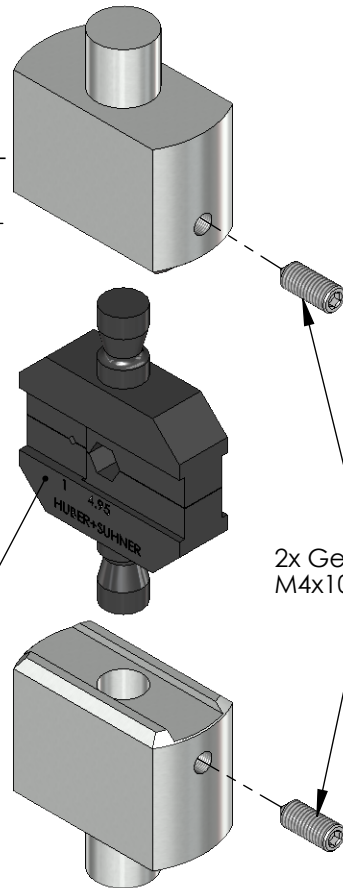

*dargestellte Crimpeinsätze optional

| Änd./ rev. index | Änderungs-Nr. / revision code | Datum/ date | Name/ name | gez./ drawn | Datum/ date | Name/ name | Gewicht/ weight [g] | Oberfläche/ surface [mm ²] | Volumen/ volume [mm ³] | Werkstoff/ material | |
|--|-------------------------------|-------------|---|-----------------------------------|-------------|----------------------|--|--|------------------------------------|---------------------|---|
| | | | | gepr./ appr. | | | ca./approx. 138.67 | ca./approx. 10287.46 | ca./approx. 23986.49 | Oberfläche/ finish | |
| | | | Maßstab/ scale | Benennung/ title | | | | | | | |
| | | | 1:1 | Werkzeughalter 4 Tool holder 4 | | | | | | | |
| Allgemeintoleranz Maße/ general tol. for dimensions DIN ISO 2768-m für Winkel mit Schenkel <1mm / for angle with side length <1mm ±3° | | | Allgemeintoleranz Form und Lage / general tolerances for geometrical features | | | Untert./ doc. type | Materialnr./ material no. | | | | Maße/ dimensions: mm Original : DIN A4 Blatt/ sheet 1 von/ of 1 |
| Toleranzangaben: Tol. x + Tol. y (Tol. x + Tol. y)/2 Tol. x + Tol. y | | | Toleranzangaben: Tol. x + Tol. y: Summe der Toleranz zweier anwendbarer Maße / Sum of the tolerance of two applicable dimensions | | | Ersatz für/ replaces | CUG 100109569 PDM Nr./ pdm no. N04100A0004 | | | | |